

LOCATION MAP
1 INCH=1000 FEET

PROJECT LOCATION

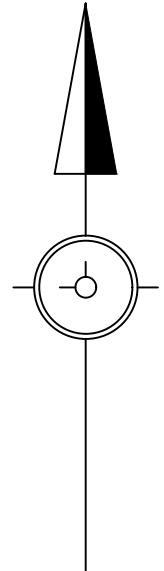

NOTES

THE RECEIVING WATERS FOR THE PROJECT IS CONEMAUGH RIVER (WWF)

LIMIT OF DISTURBANCE = 0.14 ACRES

PROJECT AREA SOILS:
 - UmB: URBAN LAND-MONOGEHELA COMPLEX, 0 TO 8 PERCENT SLOPES

SOIL LIMITATIONS / RESOLUTIONS:
 - CUTBACKS CAVE; CORROSIVE TO CONCRETE/STEEL; DEPTH TO SEASONAL HIGH WATER; LOW STRENGTH/LANDSLIDE PRONE; PIPING; FROST ACTION; SHRINK/SWELL - OBTAIN GEO-TECHNICAL STUDY TO DETERMINE APPROPRIATE RESOLUTIONS
 - POOR SOURCE OF TOPSOIL- APPLY LIME AND FERTILIZER AS NEEDED RECOMMENDED SOIL TESTING, LANDSCAPE AREAS AND PCSM BMPs MAY REQUIRE IRRIGATION
 - EASILY ERODIBLE - MINIMIZE DISTURBANCE, INSTALL STABILIZATION IMMEDIATELY AFTER GRADING, USE TEMPORARY STABILIZATION AS NEEDED
 - HYDRIC INCLUSIONS - WETLAND INVESTIGATION CONDUCTED, ANY WETLANDS HAVE BEEN DELINEATED ON THE PLAN, THERE WILL BE NO IMPACTS TO WETLAND RESOURCES.
 - DEPTH TO HIGH WATER; SLOW PERCOLATION; PONDING; WETNESS - INFILTRATION TESTING HAS BEEN CONDUCTED IN AREA OF PCSM BMPs

A LOG SHOWING DATES THAT E&S BMPs WERE INSPECTED AS WELL AS ANY DEFICIENCIES FOUND AND THE DATE THEY WERE CORRECTED SHALL BE MAINTAINED ON THE SITE AND BE MADE AVAILABLE TO REGULATORY AGENCY OFFICIALS AT THE TIME OF INSPECTION.

THE CONTRACTOR IS RESPONSIBLE FOR KEEPING THE PUBLIC ROAD FREE OF ALL MUD FROM CONSTRUCTION AND DELIVERY VEHICLES. AFTER EACH VEHICLE LEAVES THE SITE, ALL SEDIMENT DEPOSITED ON PUBLIC ROADWAYS MUST BE REMOVED AND RETURNED TO THE CONSTRUCTION SITE FOR DISPOSAL.

E&S LEGEND	
— LOD —	LIMIT OF DISTURBANCE
UmB	SOIL DESIGNATION
— (FS) —	COMPOST FILTER SOCK

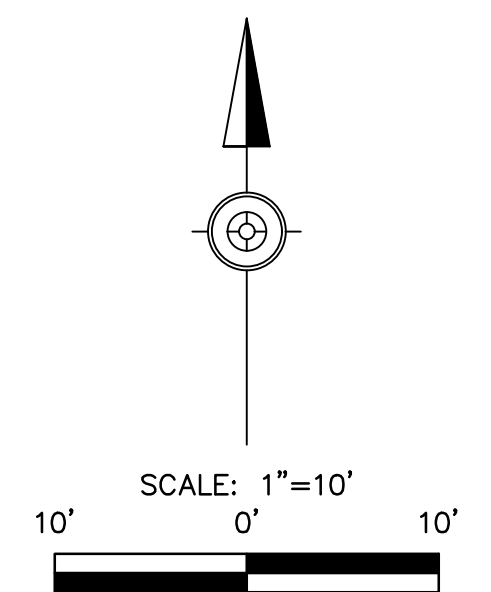

Scale: [Seal]

Date: 07-25-2025

No.	Sheet Revisions	Date

Scale	Date	Drawn By	Checked By	Project No.	File No.
AS NOTED	JULY 2025	RES	JDZ	120-23-275	5683

THE EADS GROUP

ENGINEERING ARCHITECTURE AND DESIGN SERVICES

Phone: 814.944.4035 Fax: 814.944.4862
 www.eadsgroup.com
 1201 W. 10TH ST. WILKES-BARE, PA 17257

PENNSYLVANIA / MARYLAND / WEST VIRGINIA

NEW FLORENCE PARK IMPROVEMENT PROJECT - PH 1 FOR BOROUGH OF NEW FLORENCE WESTMORELAND COUNTY, PA

EROSION AND SEDIMENTATION CONTROL PLAN

Drawing No. **ES-1**

